

ECE3411 – Fall 2015

Lecture 1b.

Introduction to Microcontrollers

General Purpose Digital Output

Marten van Dijk, Syed Kamran Haider
Department of Electrical & Computer Engineering
University of Connecticut
Email: {vandijk, syed.haider}@engr.uconn.edu

UConn



A Personal Computer

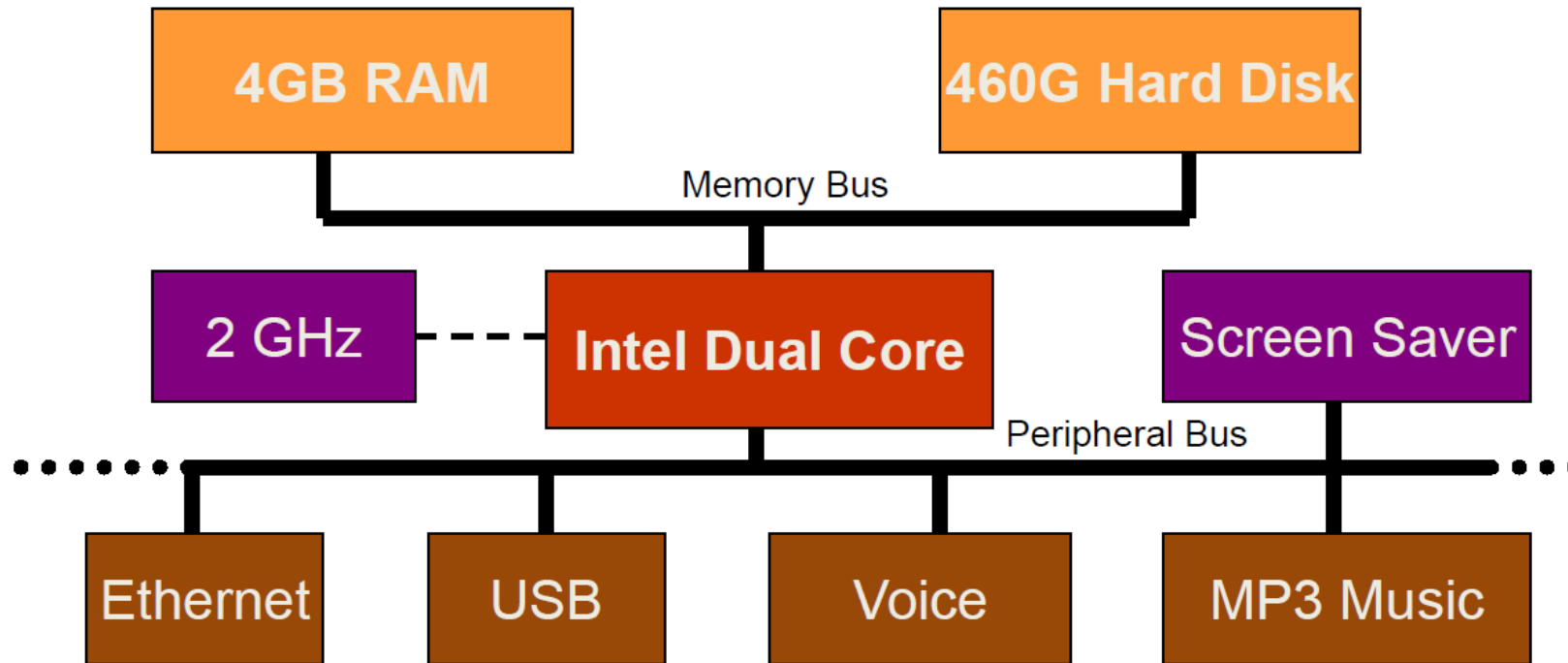

Slide from Sung Yeul Park

A Microcontroller

- A Microcontroller contains a processor core, memory and other peripherals on a single chip.

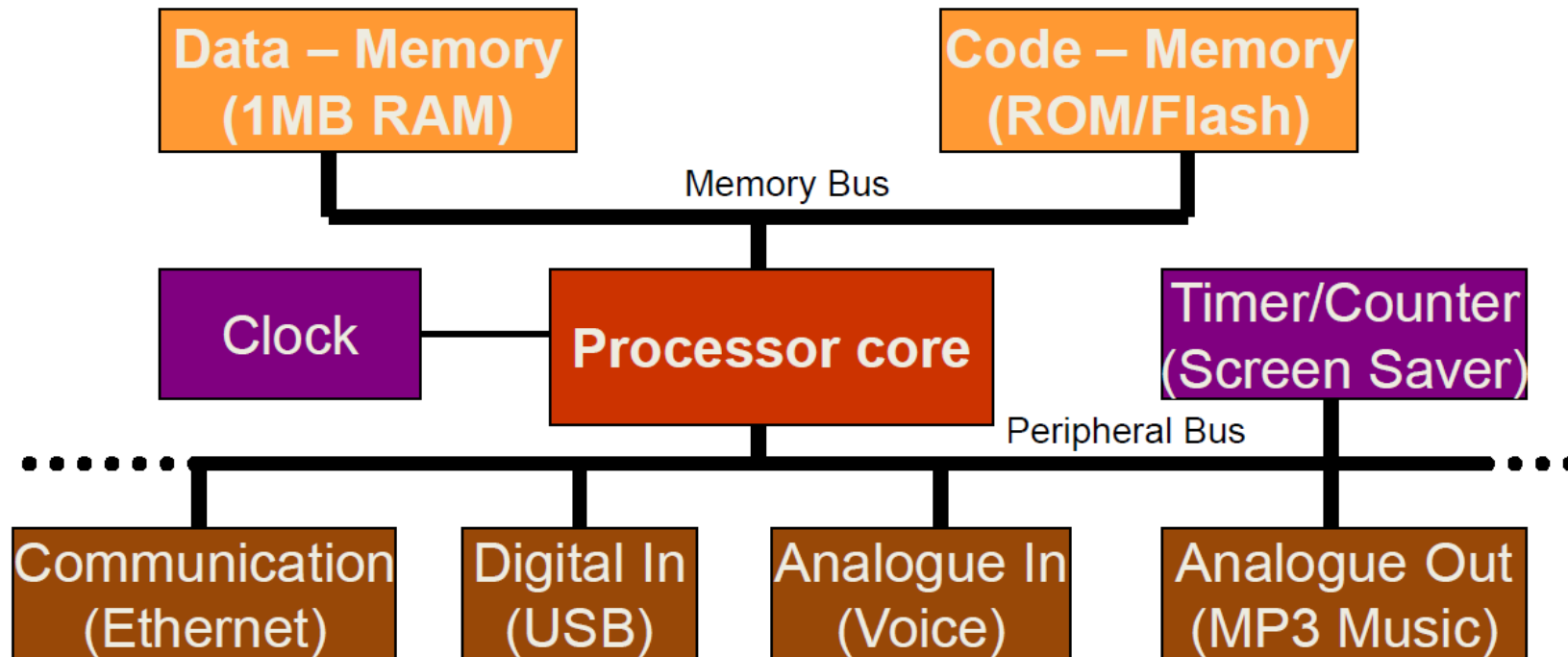

Slide from Sung Yeul Park

Microcontroller Structure

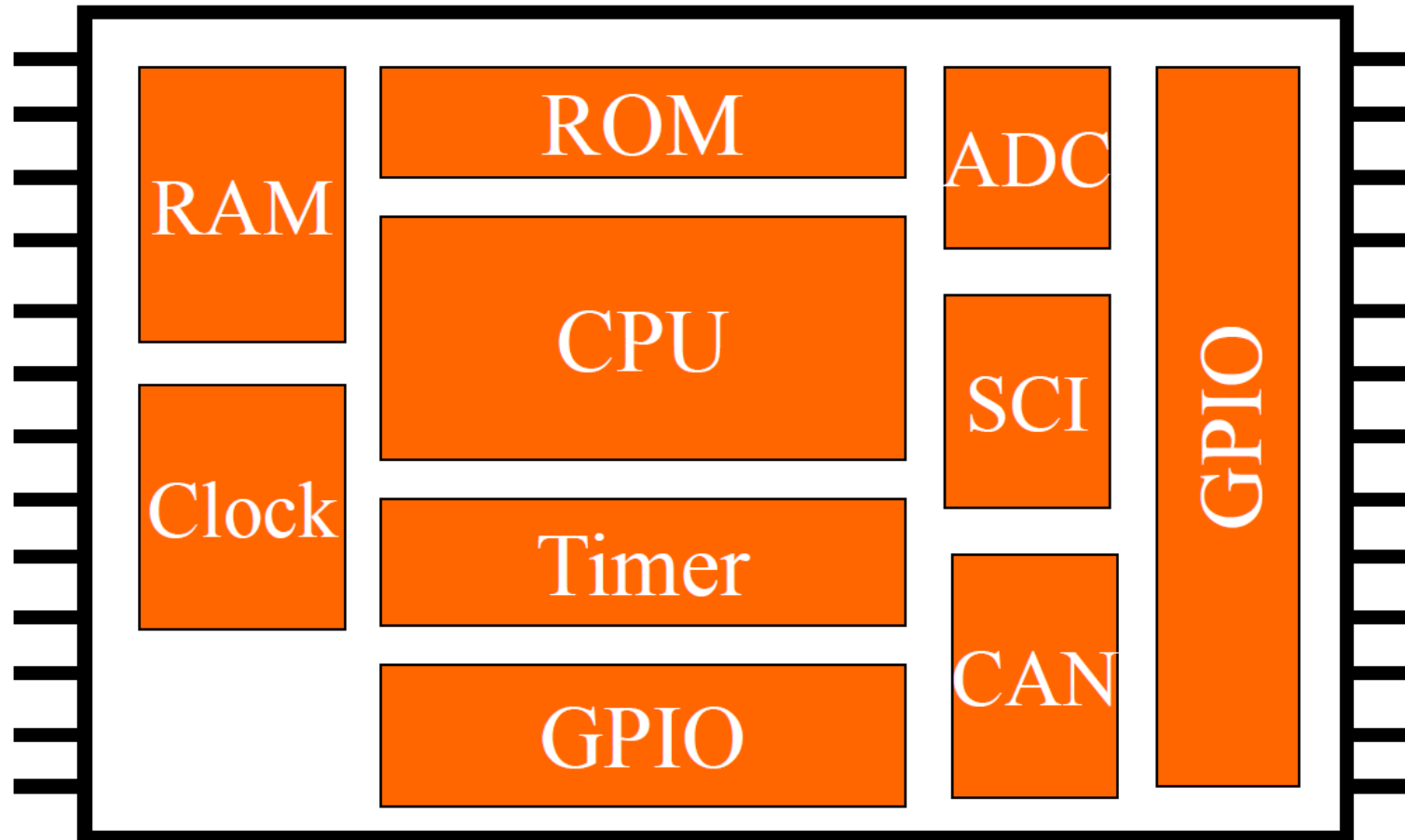

Slide from Sung Yeul Park

Atmega328P Xplained Mini Kit

- The ATmega328P Xplained Mini evaluation board provides a development platform for the Atmel ATmega328P Microcontroller.
- Target Microcontroller: ATmega328P
- On-board Programming & Debugging capability using Atmel Studio
 - Programmer Microcontroller: ATmega32U4
- USB connectivity
- Headers & Connectors for accessing target microcontroller's I/O pins

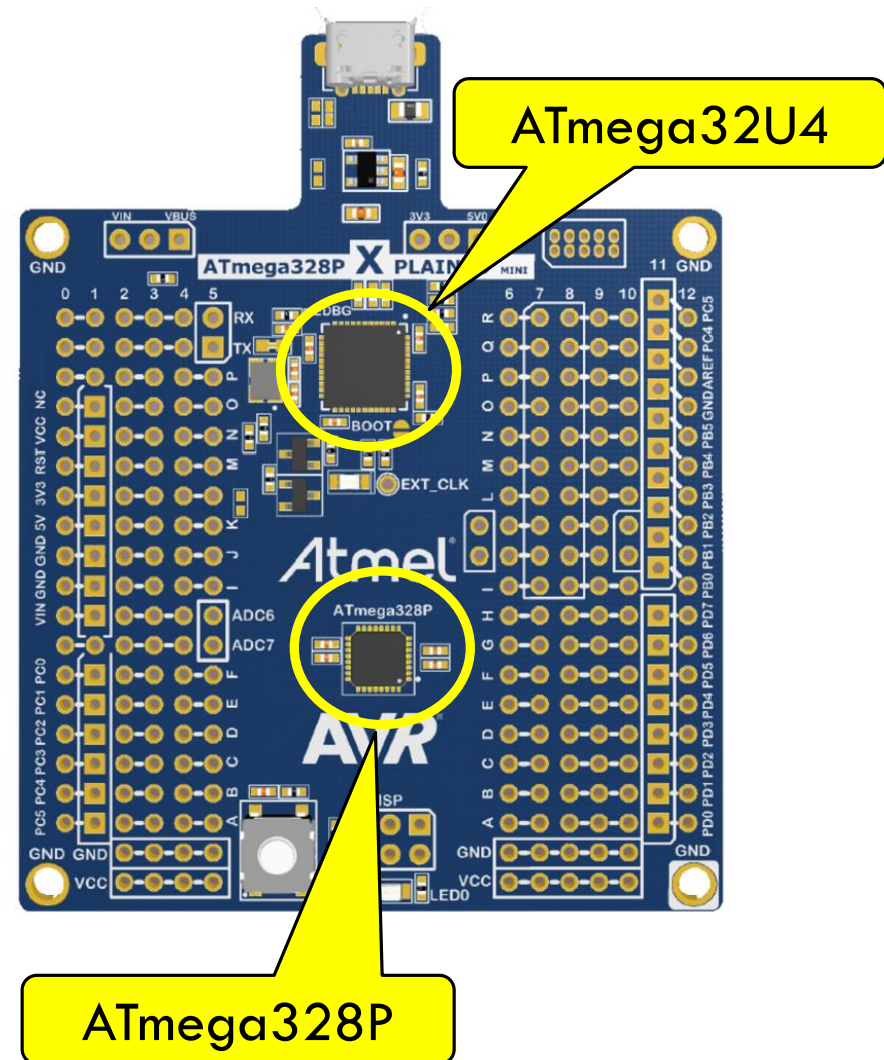

ATmega328P Features (1)

- High Performance, Low Power Atmel[®]AVR[®] 8-Bit Microcontroller
- Advanced RISC Architecture
 - 131 Powerful Instructions – Most Single Clock Cycle Execution
 - 32 x 8 General Purpose Working Registers
 - Fully Static Operation
 - Up to 20 MIPS Throughput at 20MHz
 - On-chip 2-cycle Multiplier
- High Endurance Non-volatile Memory Segments
 - 32KBytes of In-System Self-Programmable Flash program memory
 - 1K Byte EEPROM
 - 2K Bytes Internal SRAM
 - Write/Erase Cycles: 10,000 Flash/100,000 EEPROM
 - Data retention: 20 years at 85°C/100 years at 25°C
 - Optional Boot Code Section with Independent Lock Bits
 - In-System Programming by On-chip Boot Program
 - True Read-While-Write Operation
 - Programming Lock for Software Security

ATmega328P Features (2)

- Peripheral Features
 - Two 8-bit Timer/Counters with Separate Prescaler and Compare Mode
 - 16-bit Timer/Counter with Separate Prescaler, Compare Mode, and Capture Mode
 - Real Time Counter with Separate Oscillator
 - Six PWM Channels
 - 8-channel 10-bit ADC with Temperature Measurement
 - Programmable Serial USART
 - Master/Slave SPI Serial Interface
 - Byte-oriented 2-wire Serial Interface (Phillips I2C compatible)
 - Programmable Watchdog Timer with Separate On-chip Oscillator
 - On-chip Analog Comparator
 - Interrupt and Wake-up on Pin Change

ATmega328P Features (3)

- **Special Microcontroller Features**
 - Power-on Reset and Programmable Brown-out Detection
 - Internal Calibrated Oscillator
 - External and Internal Interrupt Sources
 - Six Sleep Modes: Idle, ADC Noise Reduction, Power-save, Power-down, Standby, and Extended Standby
 - Unique Device ID
- **I/O and Packages**
 - 23 Programmable I/O Lines
 - 28-pin PDIP, 32-lead TQFP, 28-pad QFN/MLF and 32-pad QFN/MLF
- **Operating Voltage: 1.8 - 5.5V**
- **Temperature Range: -40°C to 85°C**
- **Speed Grade: 0 - 20MHz @ 1.8 - 5.5V**
- **Power Consumption at 1MHz, 1.8V, 25°C**
 - Active Mode: 0.2mA
 - Power-down Mode: 0.1µA
 - Power-save Mode: 0.75µA (Including 32kHz RTC)

AVR Software Development Process

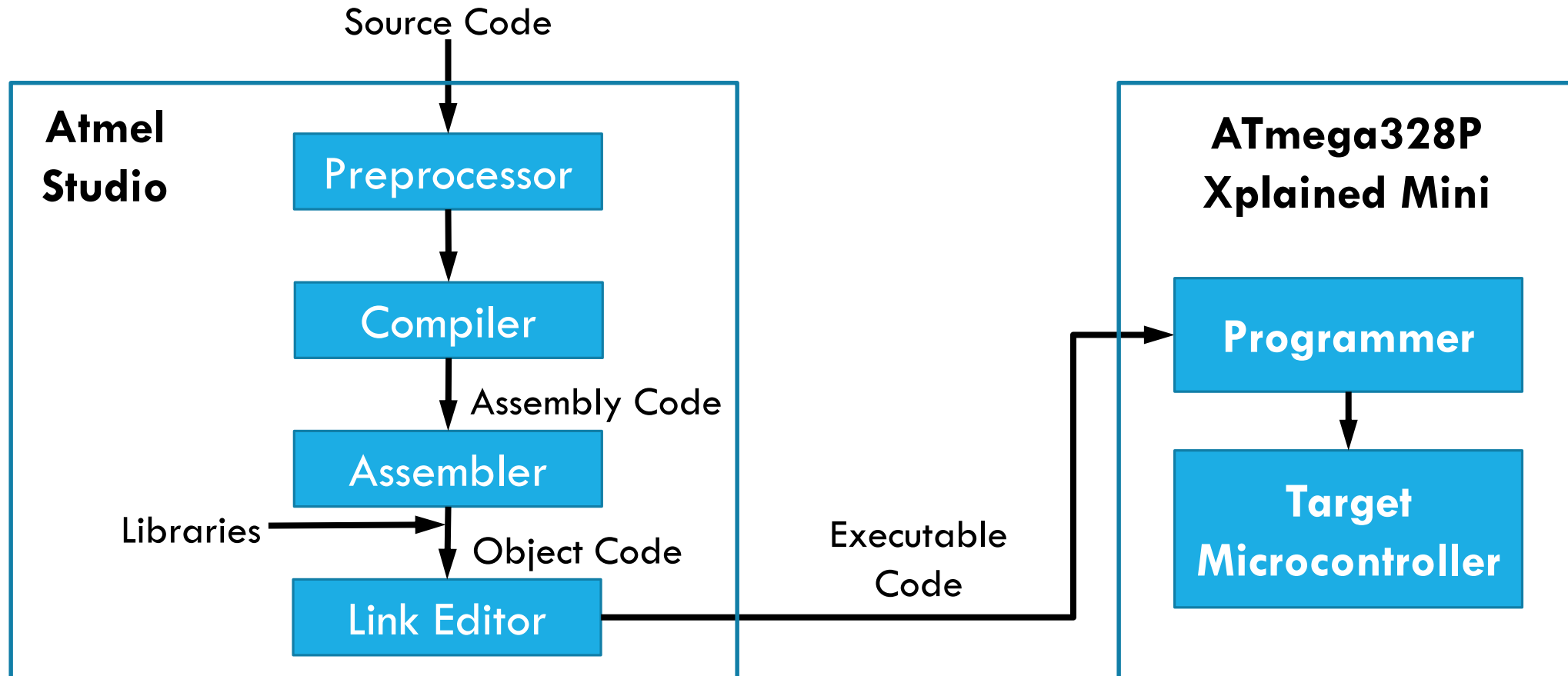

ATmega328P

32 MLF Top View

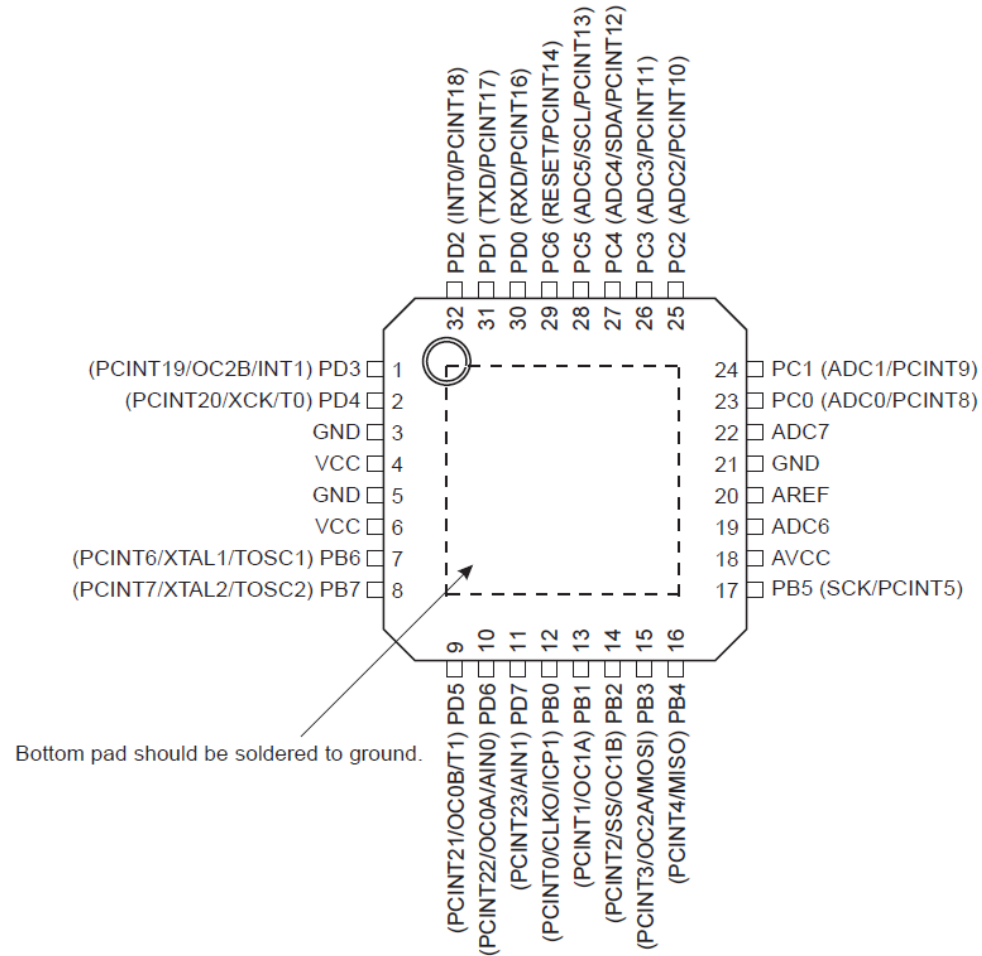

Register & Port

■ Register

- A collection of flip-flops
- Simultaneously loaded (written) in parallel or read
- Interface between users and subsystems
- Viewed as a software configurable switch

An 8-bit wide Register



■ Port

- A Port in AVR Microcontrollers represents a bank of pins.
- A port provides an interface between the central processing unit and the internal and external hardware and software components.
- E.g. PORTB, PORTC, PORTD etc.

Hardware Registers of a Port

Each Port on the Mega AVR has three hardware registers associated to it:

- **DDRx** : *Data-Direction Register for Port x*
 - Controls whether each pin is configured for input or output.
 - By default, all pins are configured as inputs.
 - E.g. to enable a pin as output, a '1' is written to its slot in the DDRx.
- **PORTx** : *Port x Data Register*
 - When the DDRx bits are set to '1' (output) for a given pin, the PORT register controls whether that pin is set to logic high or low.
 - E.g. writing a '1' to a bit position in PORT register will produce VCC voltage at that pin & vice versa.
- **PINx** : *Port x Input Pins Address*
 - The PIN register addresses are used to read the digital voltage values for each pin that's configured as input.
 - E.g. a value '0' of a bit of PIN register indicates a low voltage at that pin & vice versa.

Examples of Predefined Registers

- AVR library has some predefined register names for each port.
 - E.g. for Port B, the registers are **DDRB**, **PORTB**, and **PINB**
- These registers can be thought of as regular **variables**
 - You can read their values in your code
 - You can write values to these registers (except PINx register)
- AVR library also has predefined keywords for each bit position of each port register
 - E.g. for 7th bit position of PINB register, the predefined keyword is **PINB7**
 - Similarly **PORTB5** represents 5th bit position of PORTB register
- Notice that the keywords for bit positions are **constants**
 - They simply define the bit number, not the bit value. E.g. `PORTB5 = 5`
 - These keywords are read-only, you cannot write any value to them.

Bit Masking Operations

- Bit masking operations allow us to modify a single bit in a register
- Let's say you want to modify bit i in a register called BYTE = `0b01100000`
- To Set i^{th} bit \rightarrow `BYTE |= (1 << i);`
 - E.g. if $i = 4$ then
`BYTE |= (1 << i) \rightarrow BYTE = 0b01100000 | 0b00010000 = 0b01110000`
- To Clear i^{th} bit \rightarrow `BYTE &= ~(1 << i);`
 - E.g. if $i = 6$ then
`BYTE &= ~(1 << i) \rightarrow BYTE = 0b01110000 & ~(0b01000000)`
`BYTE = 0b01110000 & 0b10111111 = 0b00110000`
- To Toggle i^{th} bit \rightarrow `BYTE ^= (1 << i);`
 - E.g. if $i = 1$ then
`BYTE ^= (1 << i) \rightarrow BYTE = 0b00110000 ^ 0b00000010 = 0b00110010`

The Structure of AVR C Code

```
[preamble & includes]
[possibly some function definitions]
int main(void){
    [chip initializations]
    while(1) {
        [do this stuff forever]
    }
    return(0);
}
```

- The preamble is where you include information from other files, define global variables, and define functions.
- main() is where the AVR starts executing the code when the power first goes on.
- Any configurations, e.g. configuring I/O pins etc., are done in main() before the **while(1)** loop.
- **while(1)** loop represents the core functionality of the program. It keeps on executing whatever is in the loop body forever (or as long as the AVR is powered).

A Simple Test Program

```
#include <avr/io.h>
int main(void)
{
    //configure LED pin as output
    DDRB |= 1<<DDRB5;
    while(1){
        /* check the button status (press - 0 , release - 1 ) */
        if( !( PINB & (1<<PINB7) ) ) {
            /* switch off (0) the LED until key is pressed */
            PORTB &= ~(1<<PORTB5);
        }
        else {
            /* switch on (1) the LED*/
            PORTB |= 1<<PORTB5;
        }
    }
}
```

On Xplained Mini kit,

- LED is connected to 5th pin of Port B
- Switch is connected to 7th pin of Port B

(!(EXPRESSION)) means
(EXPRESSION == 0)

- Values for `PINB & (1 << PINB7)` are `0=0b00000000` or `128=0b10000000`

The Delay Library

- AVR supports a delay library to introduce delay between the execution of two code statements.
 - `<util/delay.h>` header file needs to be included in the code
- The delay library provides two functions
 - `_delay_us(x)` for introducing a delay of x microseconds
 - `_delay_ms(x)` for introducing a delay of x milliseconds
- `<util/delay.h>` library needs to know the Microcontroller's clock frequency for accurate time measurements
 - Clock frequency is defined by defining `F_CPU` in the code
- Xplained Mini kit runs the ATmega169PB on 16MHz frequency
 - `#define F_CPU 16000000UL` is included in the code to define the frequency for the delay library
- Only use delay functionality in order to define access functionality for e.g. LCD screen which requires precise timing sequences:
 - Never use delay functionality in your main program
 - We want to do other useful computation while waiting

Test Program to Blink LED

```
// ----- Preamble ----- //
#define F_CPU 16000000UL /* Tells the Clock Freq to the Compiler. */
#include <avr/io.h> /* Defines pins, ports etc. */
#include <util/delay.h> /* Functions to waste time */
int main(void) {
    // ----- Inits ----- //
    /* Data Direction Register B: writing a one to the bit enables output. */
    DDRB |= (1 << DDRB5);
    // ----- Event loop ----- //
    while (1) {
        PORTB = 0b00100000; /* Turn on the LED bit/pin in PORTB */
        _delay_ms(1000); /* wait for 1 second */
        PORTB = 0b00000000; /* Turn off all B pins, including LED */
        _delay_ms(1000); /* wait for 1 second */
    } /* End event loop */
    return (0); /* This line is never reached */
}
```